



# DIAPHRAGM VALVE / Flanged type



**DV Series**

**DF 300**  
**Size: DN15~DN250**

## MATERIALS OF CONSTRUCTION

No.	Parts	Pcs.	Materials	No.	Parts	Pcs.	Materials
1	Body	1	UPVC, PP, CPVC, PPG, PVDF	11	Grease Nipple	1	SUS304
2	Bonnet	1	PPG, PVDF	12	Stud Bolt & Nut	4	15A-25A
3	Compressor	1	15A-25A PVDF 40A-250A FC20	13	Inserted Nut	6	40A-50A
4	Hand Wheel	1	PP, ABS	14	Bolt Nut & Washer	8	65A-125A
5	Sleeve	1	15A-50A BSBM 65A-250A FC25	15	thrust Bearing	12	150A
6	Stem	1	15A-50A BSBM 65A-250A SS41	16	Stopper	16	200A
7	Diaphragm	1	EPDM, HYPALON TEFLON	17	Set Nut	20	250A
8	Cap	1	15A-25A BSBH 40A-250A PVC	18	Gauge Cover	1	Standardized 80A-250A USED ONLY
9	Compressor Pin	1	SUS-304	19	Sheet Ring	1	SS-41 BSBM SUS304
10	Name Plate	1	PVC	20	Washer	1	SS41 BSBM SUS304

Note : 1. SUS 304 .....Stainless Steel AISI 304  
4. FC 20.....Gray Cast Iron

2. SS 41 .....Rolled steel for General Structure  
5. SUP.....Steel for Spring ASTM A-230-68

3. BSBM .....Free Cutting Brass Bar

The standard material to bonnet : PPG.

Optional PVDF bonnet material for PVDF diaphragm valve.

Optional materials on request for part no. 4.5.6.12.14.: SUS 304 or SUS 316.

©VITON & TEFLON are trademarks of E. I. Du Pont

## DIMENSIONS TABLE

Nom. Size n/m (inch)	JIS											PRESS Test for Assembly (at 20°C)										
	Unit: mm											Test Pressure Unit: kg/cm <sup>2</sup>										
	D1	D2	D3	ε	n No. of holes	D4	D5	Lift ℓ	L	T	H	I	Rubber Diaphragm					Teflon Diaphragm				
													UPVC	PP	PPG	CPVC	PVDF	UPVC	PP	PPG	CPVC	PVDF
15(1/2")	16	70	95	15	4	59x53	94	13	110	15	101	140	10	10	10	10	10	10	7	7	10	7
20(3/4")	20	75	100	15	4	74x63	94	13	120	16	106	152	10	10	10	10	10	10	7	7	10	7
25(1")	25	90	125	19	4	80x66	94	14	130	16	113	158	10	10	10	10	10	10	7	7	10	7
40(1 1/2")	41	105	140	19	4	126	147	24	180	17	133	193	10	10	10	10	10	7	7	7	7	7
50(2")	52	120	155	19	4	148	147	28	210	17	145	210	10	10	10	10	10	7	7	7	7	7
65(2 1/2")	68	140	175	19	4	190	202	32	250	22	197	276	10	10	10	10	10	7	7	7	7	7
80(3")	78	150	185	19	8	215	202	34	280	22	218	293	10	10	10	10	10	6	5	6	6	6
100(4")	100	175	210	19	8	255	241	54	340	22	261	370	10	10	10	10	10	6	5	6	6	6
125(5")	125	210	250	23	8	320	274	72	410	24	308	412	7	7	7	7	7	5	4	4	5	5
150(6")	148	240	280	23	8	385	395	72	480	30	334	471	7	7	7	7	7	5	4	4	5	5
200(8")	198	290	330	23	12	430	395	96	570	30	419	625	4	4	4	4	4	3	3	3	3	3
250(10")	248	355	400	25	12	540	555	132	680	32	510	750	4	3	4	4	4	3	3	3	3	3



CV VALUE	
CV	[GMP/(1lbf/in <sup>2</sup> ) <sup>1/2</sup> ]
Full Open: 100%	
diametro	CV
1/2"	3.27
3/4"	5.29
1"	8.87
1-1/2"	31.09
2"	43.15
2-1/2"	90.68
3"	116.79
4"	186.78
6"	345.26

BOLTS TORQUE VALUE		
SIZE	Kg.m	N.m
1/2"	90	8.83
3/4"	110	10.79
1"	110	10.79
1-1/2"	150	14.72
2"	220	21.58
2-1/2"	220	21.58
3"	280	27.47
4"	280	27.47
6"	280	27.47

1Kg.m=0.0981N.m

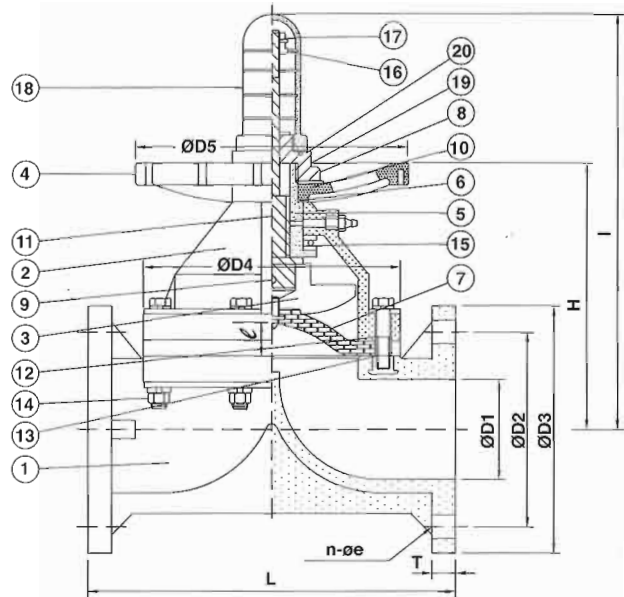

### DIMENSIONS TABLE

ANSI													PRESS Test for Assembly ( at 20°C)										
Nom. Size m/m(Inch)	D1	D2	D3	e	n No. of holes	D4	D5	Lift ℓ	L	T	H	I	Test Pressure Unit: psi										
													Rubber Diaphragm					Teflon Diaphragm					
													UPVC	PP	PPG	CPVC	PVDF	UPVC	PP	PPG	CPVC	PVDF	
15(1/2")	0.63	2.38	3.50	0.63	4	2.32x2.09	3.70	0.51	4.25	0.59	3.98	5.51	150	150	150	150	150	150	105	105	105	105	105
20(3/4")	0.79	2.76	3.86	0.63	4	2.80x2.48	3.70	0.51	5.90	0.63	4.17	5.98	150	150	150	150	150	150	105	105	105	105	105
25(1")	0.98	3.13	4.25	0.63	4	31.5x2.60	3.70	0.55	5.90	0.63	4.45	6.22	150	150	150	150	150	150	105	105	105	105	105
40(1 1/2")	1.61	3.88	5.00	0.63	4	4.96	5.79	0.94	6.95	0.67	5.24	7.60	150	150	150	150	150	105	105	105	105	105	105
50(2")	2.05	4.74	5.98	0.75	4	5.83	5.79	1.10	7.95	0.67	5.71	8.27	150	150	150	150	150	105	105	105	105	105	105
65(2 1/2")	2.68	5.49	7.01	0.75	4	7.48	7.95	1.26	9.85	0.87	7.76	10.87	150	150	150	150	150	105	105	105	105	105	105
80(3")	3.07	6.00	7.52	0.75	4	8.46	7.95	1.34	10.40	0.75	8.50	11.54	150	150	150	150	150	90	75	90	90	90	90
100(4")	3.94	7.50	9.02	0.75	8	10.04	9.49	2.13	12.95	0.91	10.28	14.57	150	150	150	150	150	90	75	90	90	90	90
125(5")	4.92	8.50	10.00	0.87	8	12.60	10.79	2.83	16.14	0.94	12.13	16.22	105	105	105	105	105	75	60	60	75	75	75
150(6")	5.83	9.51	10.98	0.87	8	15.16	15.55	2.83	18.90	1.18	13.15	18.54	105	105	105	105	105	75	60	60	75	75	75
200(8")	7.80	11.75	13.50	0.87	8	16.93	15.55	3.78	22.44	1.26	16.40	24.61	60	60	60	60	60	45	45	45	45	45	45
250(10")	9.76	14.25	15.98	0.98	12	21.26	21.85	5.20	26.77	1.26	20.08	29.53	60	45	60	60	60	45	45	45	45	45	45

DIN													PRESS Test for Assembly ( at 20°C)										
Nom. Size m/m(Inch)	D1	D2	D3	e	n No. of holes	D4	D5	Lift ℓ	L	T	H	I	Test Pressure Unit: kgf/cm <sup>2</sup>										
													Rubber Diaphragm					Teflon Diaphragm					
													UPVC	PP	PPG	CPVC	PVDF	UPVC	PP	PPG	CPVC	PVDF	
15(1/2")	16	65	95	14	4	59x53	94	13	130	23	101	140	10	10	10	10	10	10	7	7	10	7	7
20(3/4")	20	75	105	14	4	74x63	94	13	150	23	106	152	10	10	10	10	10	10	7	7	10	7	7
25(1")	25	85	115	14	4	80x66	94	14	160	23	113	158	10	10	10	10	10	10	7	7	10	7	7
40(1 1/2")	41	110	150	18	4	126	147	24	200	23	133	193	10	10	10	10	10	7	7	7	7	7	7
50(2")	52	125	165	18	4	148	147	28	230	21	145	210	10	10	10	10	10	7	7	7	7	7	7
65(2 1/2")	68	145	185	18	4	190	202	32	290	22	197	276	10	10	10	10	10	7	7	7	7	7	7
80(3")	78	160	200	18	8	215	202	34	310	22	218	293	10	10	10	10	10	6	5	6	6	6	6
100(4")	100	180	220	18	8	255	241	54	350	25	261	370	10	10	10	10	10	6	5	6	6	6	6
125(5")	125	210	250	18	8	320	274	72	400	24	308	412	7	7	7	7	7	5	4	4	5	5	5
150(6")	148	240	285	23	8	385	395	72	480	30	334	471	7	7	7	7	7	5	4	4	5	5	5
200(8")	198	295	340	23	8	430	395	96	600	32	419	625	4	4	4	4	4	3	3	3	3	3	3
250(10")	248	350	395	23	12	540	555	132	680	32	510	750	4	3	4	4	4	3	3	3	3	3	3

※ Standard dimensions based on PVC material